

UTAH

UST OWNER/OPERATOR GUIDANCE DOCUMENT

195 North 1950 West
Salt Lake City, Utah 84114
801-536-4100
www.undergroundtanks.utah.gov



Developed by the Department of
Environmental Quality–Underground
Storage Tank Section

Jan 25, 2017

Table of Contents

• Regulations	3
• UST Operator	4
• UST System Components	13
• Release Prevention	24
• Leak Prevention	36
• Testing Requirements	40
• UST Operator Inspection	46
• State Compliance Inspection	51
• Notification	52
• Financial Responsibility	53
• Installation Permit	54
• Red Tag and One Time Drop	55
• Certificate of Compliance	56
• Closures	57
• Release Response	60
• Fee Schedule	62



Regulations

- Energy Policy Act of 2005 initiated UST Operator Training Requirements
- 40CFR 280 Code of Federal Regulations cover the installation, operation and closure of USTs
- UST ACT, Utah Code Annotated (UCA), Section 19-6-407 and R311 authorizes the Division of Environmental Response and Remediation to administer the Utah UST program



ABC UST OPERATOR

Class A Operator – an owner, operator, employee, or individual designated under Subsection R311-201 that has primary responsibility for the broader aspects of the statutory and regulatory requirements and standards necessary to operate and maintain the UST system

Class B Operator – an owner, operator, employee, or individual who will implement routine daily aspects of operation, maintenance, and recordkeeping for UST systems

Class C Operator – an employee who is generally the first line of response to events indicating emergency conditions



Class A Operator Responsibilities

- Have a general knowledge of UST systems
- Ensure that UST records are properly maintained
- Ensure proper response to and reporting of emergencies caused by releases or spills from USTs
- Ensure that class B and class C operators are trained and registered
- Ensure that annual UST fees are paid
- Maintain UST system records



Class B Operator Responsibilities

- Ensure that on-site UST operator inspections are conducted according to the requirements of Subsection R311-201-12
- Ensure that UST release detection is performed
- Ensure that the status of the UST system is monitored for alarms and unusual operating conditions
- Perform required Utah monthly inspections
- Ensure that proper release detection and other records are kept and made available for inspection
- Ensure that spill prevention, overflow prevention, and corrosion protection requirements are met
- Be present for any compliance inspections, or designate another qualified individual
- Ensure that suspected releases are properly documented
- Ensure that class C operators are trained and documented and present during UST operation hours



Utah Third Party Class B Operators

- Shall be trained and registered in accordance with Subsection R311-201-12 and shall be certified in accordance with R311-201-12 as:
 - An UST Tester, or
 - An UST Installer as either a general installer or service/repair technician, or
 - Meet the training requirements of a certified UST inspector and document comprehensive or general liability insurance with limits of \$250,000 minimum per occurrence



Class C Operator Responsibilities:

- Be present at the site at all times during normal operating hours
- Monitor product transfer operations to ensure that spills and overfills do not occur
- Properly respond to alarms, spills, and overfills
- Notify class A and/or B operators and appropriate emergency responders when necessary
- Act in response to emergencies and other situations caused by spills or releases from an UST system that pose an immediate danger or threat to the public or to the environment, and that require immediate action



UST Operator Training and Registration Requirements

Training

- Class A, B and C operators must be trained
- Class A and B operators must successfully complete an approved training course within 30 days of assuming work duties
- Class B operators may train a C operator

Registration

- A and B operators must
 - Complete an approved training course
 - Pass State administered examination
 - Submit an application
 - Pay applicable fees
- C operators
 - No registration or fees are required for the class C operators



Renewal and Reciprocity

Renewal of Registration

- Class A and B operators must apply for renewal of registration every three years
- Pay applicable fees
- No class or test is required
- If an applicant's registration has lapsed for more than two years, the applicant must go through the registration process as if it were their initial registration

Reciprocity

- If the DERR determines that another state's operator training program is equivalent to Utah's program, it may be accepted in lieu of the Utah program with the following provision:
 - Must take the state approved examination
 - Must submit a registration application and pays fees



Violations requiring Re-training

- Class A operator may require re-training within 90 days if the facility is found to be out of compliance due to:
 - Lapsing of the Certificate of Compliance
 - Failure to provide acceptable financial responsibility
 - Failure to ensure that the class B or C operators are trained and registered
- Class B operator may require re-training within 90 days if the facility is found to be out of compliance due to:
 - Failure to maintain spill and overfill prevention
 - Failure to maintain corrosion prevention
 - Failure to maintain leak prevention
 - Failure to perform UST operator monthly inspections
 - Failure to ensure that the class C operators are trained, registered and on site during facility operation hours



Re-training Requirements

- Re-training must occur within 90 days of violation
- Class A and B operators must successfully complete an approved training course, pass an examination, submit an application and pay fees
- If the documentation of training is not received, the facility's Certificate of Compliance may be revoked (R311-201)



UST SYSTEM COMPONENTS

UST SYSTEM

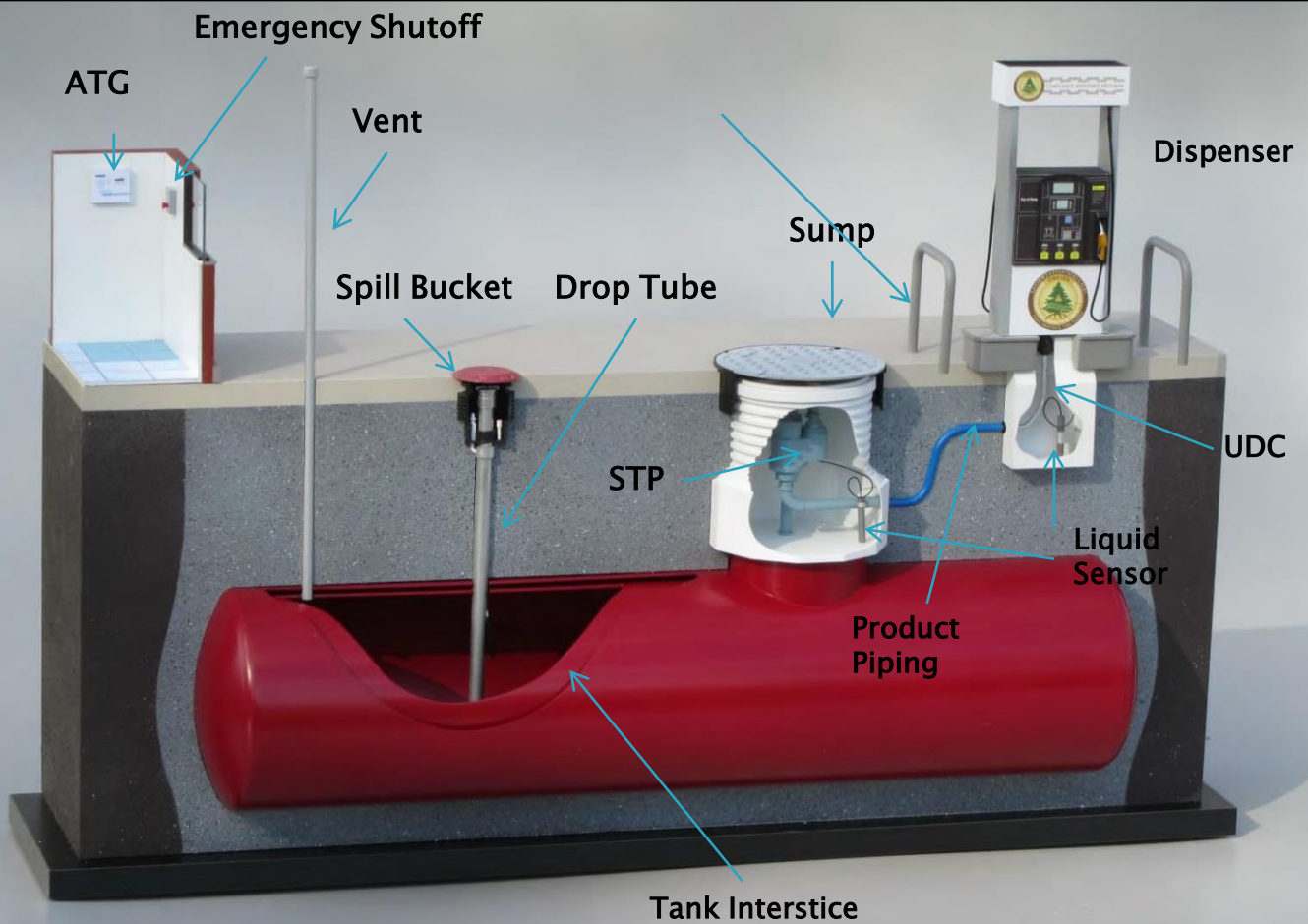

Construction of Tanks

- Fiberglass Reinforced Plastic (FRP)
- Composite – clad or jacket
- Steel – cathodically protected and/or lined
- Single or double walled

All tanks installed after Oct 2008 must be double walled and perform interstitial monitoring. This includes Emergency Generator Tanks.



UST SYSTEM COMPONENTS - TANKS

Double-Walled (DW) USTs

- Interstice can be equipped with an interstitial sensor for release detection
- DW Tanks usually have an interstitial riser which is accessible from the tank top
- A DW tank interstice can be either dry, or contain a brine solution



Tank Interstitial Riser

Sensor

Brine Reservoir



UST SYSTEM COMPONENTS - UDCs

Under Dispenser Containment (UDC)

- Containment sump under dispensers prevent fuel from reaching the soil
- Shear Valves – prevent hazards caused by collision or fires at the dispenser when properly anchored
- Liquid Sensors – Detect liquid in the containment sumps

Update

- Dispensers installed after Oct 2008 must have under-dispenser containment. UDCs must be liquid-tight on its sides, bottom, and at any penetrations. UDCs must allow for visual inspection and access to the components in the containment system or be periodically monitored for leaks from the dispenser system
- All single-walled UDCs that are used as part of an interstitial monitoring system must be tested by Oct 13, 2018 and every three years thereafter



Shear Valve



UST SYSTEM COMPONENTS - SUMPS

Tank Top Containment Sumps

- Prevent product released from the piping, Submersible Turbine Pump (STP) or other components from reaching the soil or groundwater
- Must be liquid-tight on its sides, bottom and at all penetrations

Update

- No later than Oct 13, 2018 you must perform your first three-year liquid tightness test on single-walled tank top containment sumps and any other single-walled sump used for interstitial monitoring of piping



Automatic Tank Gauge (ATG)

- An ATG system consists of a probe permanently installed in a tank and wired to a monitor to provide information on product level and temperature
- An ATG monitoring system can provide operators with alarm and sensor status, inventory, and some can perform leak detection testing
- Common ATG systems are Veeder-Root and Incon
- **ATGs must be functionality tested by Oct 13, 2018 and every year thereafter (see p. 40)**



Automatic Tank Gauge Systems:

(ATG may provide one or more of the following)

- Monitor the tank inventory electronically via an in-tank probe
- Provide in-tank release detection using the in-tank probe
- Provide interstitial monitoring on the tank using a sensor
- Monitor the interstitial piping using a containment sump sensor
- Monitor piping release detection via an electronic line leak detector
- Monitor Under Dispenser Containment (UDC) and containment sump sensors

Sump Sensor



ATG In-tank Probe



UST SYSTEM COMPONENTS – Vapor Recovery

Vapor Recovery

- Stage I Vapor Recovery collects vapors at the tank top and is required at most gasoline dispensing facilities
- Stage II Vapor Recovery collects vapors at the dispenser/vehicle, and is not required in Utah



UST SYSTEM COMPONENTS – Vapor Recovery

Two Point Vapor Recovery

- Two Point Vapor Recovery consists of two attachment points (one for liquid delivery and one for vapor return to the truck)



UST SYSTEM COMPONENTS – Vapor Recovery

Single Point Vapor Recovery

- Coaxial, or Single-Point Vapor Recovery System – the filling and vapor consist of a single attachment point

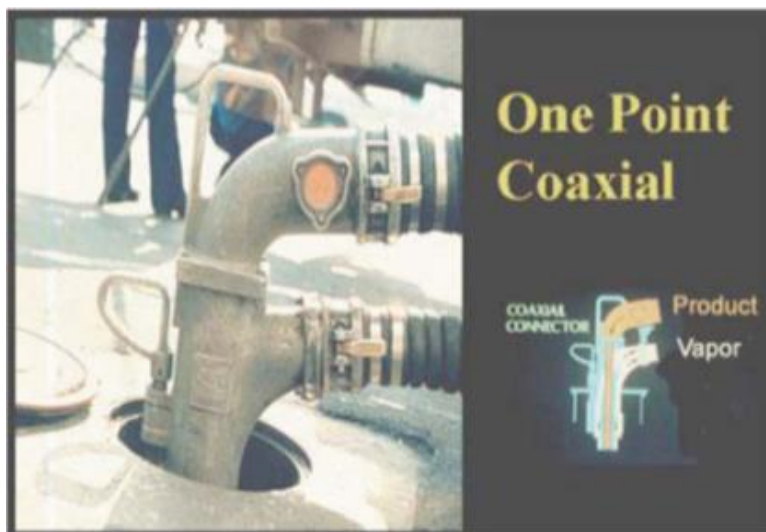

UST SYSTEM COMPONENTS – Vapor Recovery

- Pressure vent caps are required as part of the Vapor Recovery System



Spill, Overfill and Corrosion Protection

- **Spill Prevention**-is containment around the fill pipe that catches small spills that occur during delivery
- **Overfill Prevention** – devices either shut off product flow, restrict product flow or alert the delivery operator with an alarm when the tank is close to being full
- **Corrosion Prevention** – a system designed to protect a steel tank and piping from corrosion



RELEASE PREVENTION – Spill Prevention

Spill Buckets

- Liquid tight containment that surrounds the fill pipe
- Spill Buckets typically range in size from 5 to 25 gallons
- There is no minimum capacity requirement for spill buckets
- USTs that receive 25 gallons or less per delivery do not require a spill bucket
- Must be clean and dry, free of debris, no holes or cracks or deformation

Update

- You must test or monitor your spill prevention equipment
 - Single-walled Spill Buckets must be tested at least every three years for liquid tightness. The test must be conducted according to a code of practice or manufacturer's instructions
 - Double-walled Spill Buckets may not require testing if they conduct periodic interstitial monitoring.
- You must inspect your spill prevention equipment at least every 30 days as part of your walk through inspection (or before each delivery if you receive deliveries less frequent than every 30 days)



RELEASE PREVENTION - Overfill

Overfill Protection

- Is designed to stop product flow, reduce product flow or alert the delivery person that the tank is almost full
- Overfill prevention equipment must automatically shut off when the tank is no more than 95% full
- Overfill devices are not required with transfers of fuel 25 gallons or less

Update

- No later than Oct 13, 2018 you must inspect your overfill prevention equipment at least once every three years to ensure it will function properly to prevent overfills
- The inspection must be conducted according to a code of practice or manufacturer's instructions

Three types of overfill protection

- High level alarm
- Automatic shut off
- Ball float valve



Overfill Alarm

- Alert the delivery driver to an overfill with an alarm when the tank reaches 90% of fuel capacity
- Must be located where the driver can see and hear it easily
- Must be identified with a sign



Automatic Shutoff

- Often called Flapper Valve or Butterfly Valve
- Shut off device installed in the tank's fill pipe or drop tube
- Stops the flow of fuel into the UST when the fuel level reaches 95% capacity

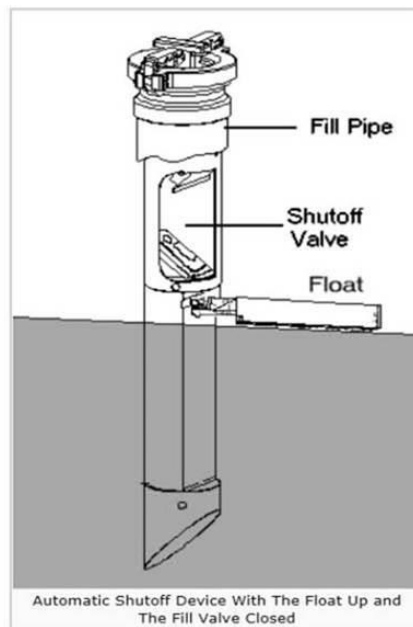
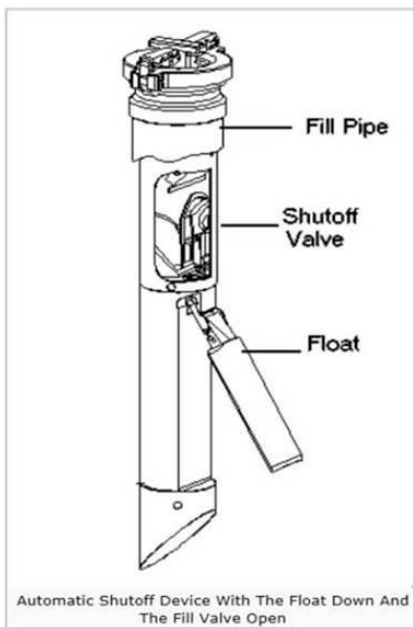

Ball Float Device

- Installed in the bottom of the vent line in the UST
- Restricts the flow of fuel during deliveries but does not shut off the flow
- The ball rises with the liquid level in the tank until the vent line is blocked, preventing air from exiting the tank and thus restricting the flow of fuel into the tank
- Ball Floats cannot be installed on new installations
- Ball Floats cannot be replaced or repaired
- If the Ball Float goes bad or cannot be tested, it must be replaced with another form of Release Prevention



RELEASE PREVENTION – Corrosion Protection

Corrosion Protection

- Cathodic protection on metallic components will help prevent the UST system from corroding and leaking product into the environment.
- All portions of the UST system that routinely contain product must be :
 - Constructed of a non-metallic material or
 - Isolated from the ground or
 - Be cathodically protected



Fiberglass Tanks



Steel Tank



RELEASE PREVENTION – Corrosion Protection

Corrosion Protection

- There are two forms of corrosion protection:
 - Galvanic
 - Impressed current (Rectifier)



RELEASE PREVENTION – Corrosion Protection

Galvanic

- Galvanic uses a coating along with an anode composed of magnesium or zinc attached to the tank



Steel Tank with
anode



RELEASE PREVENTION – Corrosion Protection

Impressed Current

- Impressed Current uses a rectifier and anodes to protect metal tanks and piping
- The rectifier must remain on 24 hours a day



RELEASE PREVENTION – Corrosion Protection

Flex Connectors

- Flex Connectors – are a flexible braided piping, usually found under the dispenser or at the tank top sump
- Three ways to protect Flex Connectors
 - Not in contact with the soil
 - Booted
 - Cathodically protected



Flex Connector at a dispenser



RELEASE PREVENTION – Corrosion Protection

Corrosion Protection Testing Requirements

- Must be tested within 6 months of installation and every three years by a Utah Certified CP tester
 - Must maintain the last two surveys done by a certified cathodic protection tester
- All repair records must be kept for the life of the UST system
- Impressed Current Systems (Rectifier) must be monitored every 60 days
 - Document that the rectifier is on by initialing or signing the log
 - The last 3 system checks must be maintained for compliance inspections



General Requirements

- Tanks must be monitored for releases at least every 30 days using a proper release detection method
- Your release detection method must be able to detect a release from any portion of the tank and connected underground piping that routinely contains product
- Release detection must be installed, calibrated, operated, and maintained according to the manufacturer's instructions
- All UST systems (including Emergency Generator Tanks) installed after Oct 2008 must have secondary containment and perform interstitial monitoring

Permanent Forms of Leak Detection are:

- Automatic Tank Gauging (ATG)
- Interstitial Monitoring (IM)
- Statistical Inventory Reconciliation (SIR)
- Groundwater and Vapor Monitoring (Contact the UST section if you have questions)

Non-Permanent Forms of Leak Detection are:

- Inventory Control with Tank Tightness Testing
- Manual Tank Gauging with Tank Tightness Testing



LEAK PREVENTION – TANKS

Automatic Tank Gauging (ATG)

- Consists of a probe permanently installed in a tank and wired to a monitor to provide information on product level and temperature
- ATG systems automatically calculate the changes in product volume that can indicate a leak
- The tank must contain a minimum amount of product to perform a valid test according to the manufacturer's specifications
- Have an owner's manual on site
- Keep the results of your ATG system monthly tests for 3 years
- **ATGs must be functionality tested by Oct 13, 2018 and once a year thereafter (see p. 40)**



Example of an ATG monitor



Automatic Tank Gauging (ATG)

Two types of ATG monitoring

- Continuous In-tank Leak Detection
 - Continuous monitoring
 - Allows for around the clock fueling
- Static/Shutdown Testing
 - Requires the system to be shut down for a required amount of time for testing

PASS – FAIL – INCONCLUSIVE

- **Pass** - Everything is OK
- **Fail** - If you get a failed monthly test (.2gph test) it must be justified within 24 hours
 - Run another test
 - Contact your service provider for assistance
 - If a failed test cannot be justified the DERR may require additional follow-up and a tank tightness test
- **Inconclusive/other than Pass or Fail**
 - Contact your service provider for assistance



Interstitial Monitoring

- All new tank installations must have secondary containment on tanks and piping and perform interstitial monitoring
- Secondary containment provides a barrier between the tank and the environment
- Monitors are used to check the area between the tank and the barrier for leaks and alert the operator if a leak is suspected
- Keep liquid status reports for each month

Sensor Reports

- “Normal” is good
- Anything other than “normal” means there is a problem
- In many cases the monitor will signal an alarm
- Contact your maintenance provider
 - If the alarm can not be justified contact the DERR within 24 hours



LEAK PREVENTION – TANKS

Testing Requirements for electronic and mechanical leak detection components

Update

You must perform annual functionality tests on all line leak detectors (LLD)

- Mechanical LLD already have this requirement
- Electronic LLD must be tested at installation and annually beginning Oct 13, 2018

No later than Oct 13, 2018 you must perform your first annual release detection equipment test on mechanical and electronic components, including: automatic tank gauges and other controllers, monitors, probes, sensors.

- ATG and other controllers
 - Test alarm
 - Verify system configuration
 - Test battery backup
- Probes and Sensors
 - Inspect for residual build up
 - Ensure floats move freely
 - Ensure it is not damaged
 - Ensure cables are free of kinks and breaks
 - Test alarm and communication with controller
- Automatic Line Leak Detectors (electronic and mechanical) must be tested by simulating a leak

Tests must be performed according to the manufacturer's instructions, or a code of practice developed by a nationally recognized association or independent testing laboratory.



Statistical Inventor Reconciliation (SIR)

- SIR uses sophisticated computer software to conduct a statistical analysis of inventory, delivery and dispensing data
- You must supply the SIR provider with data each month
- Most SIR methods analyze both tanks and lines
- Two ways to collect data
 - Manually stick the tank
 - Using an ATG or other tank monitoring system

Pass – Fail - Inconclusive

- **Pass** – Is good
- **Fail** – If you get a failed monthly test you must contact the DERR within 24 hours and do the following:
 - Start an investigation
 - Contact your service provider for assistance
 - You have 7 days to justify the “fail”
 - If the fail cannot be justified the DERR may require a tank tightness test or additional investigation
- **Inconclusive** – Two consecutive inconclusive tests will be treated as a **Failed Test**.



Inventory Control and Tank Tightness Testing

Inventory control involves taking measurements of tank contents and recording the amount of product pumped each operating day, measuring and recording tank deliveries, and reconciling all this data at least once a month.

- This method includes tank tightness testing annually
- Can be used for tanks installed after 1998 and before 2008

Manual Tank Gauging

- Involves taking the tank out of service each week (up to 36 hours at a time) during which the contents are measured twice at the beginning and end of the test period
- The measurements are compared to a weekly and monthly standard to determine if the tank is tight



LEAK PREVENTION – Piping

Two Methods of Fuel Dispensing

- Pressurized piping – uses a submersible turbine pump (STP)
- Suction
 - Safe Suction Piping
 - US Suction



STP – pressurized



pump under dispenser –
suction



LEAK PREVENTION – Line Leak Detectors

Line Leak Detectors are designed to detect a catastrophic release from pressurized piping

- Mechanical (restricts product flow)
- Electronic (shuts off product flow)
- **Both Electronic and Mechanical Leak Detectors must be tested for functionality/simulated leak test at installation and every year by a certified UST tester**



Electronic LLD

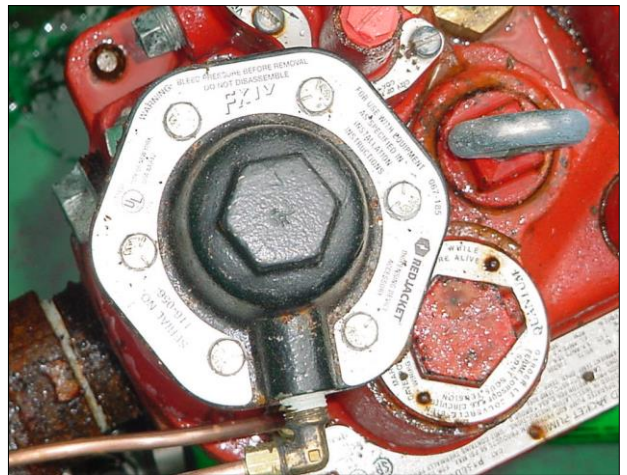

Mechanical LLD



Piping Testing Requirements

- **Pressurized** (Pressurized piping must have a Leak Detector and one of the following forms of leak detection)
 - Annual line tightness test at .1 gph leak rate at 1.5 times the operating pressure of the product line
- **Or**
 - Monthly monitoring (.2 gph, using Interstitial Monitoring or SIR)
 - The ELLD has performed a .2 gph test, at least once a month for 12 months
 - IM – liquid status report printed or manual log completed at least once a month for 12 months
 - SIR reports available for the past 12 months
- **Suction – Two types**
 - US suction – has a check valve at the tank, requires a line test every 3 years
 - Safer Suction – release detection is not required for safe suction if the system operates at less than atmospheric pressure, the piping slopes back toward the tank and there is only one check valve in the system located under the dispenser

Note: All line tightness tests and leak detector tests must be performed by a Utah certified UST tester.



Monthly Inspections

- By rule, each UST facility must have an on site operator inspection every 30 days
- The inspection must be performed by or under the direction of the designated class B operator
- The class B operator must sign all monthly inspection forms
- Must use the approved UST Operator Inspection – Utah form found on the DERR website or another form approved by the DERR
 - This form is effective January 1, 2017



UST OPERATOR INSPECTIONS

UST Operator Inspection - Utah YEAR _____

Facility Name		Facility ID											
Address		Primary Class B Operator											
NAME(S) AND INITIALS OF PERSON(S) CONDUCTING MONTHLY INSPECTIONS:													
Please respond to <u>ALL</u> of the following questions with a Y (Yes), N (No), or NA (Not Applicable) answer.													
Months of the Current Year		J	F	M	A	M	J	J	A	S	O	N	D
Monthly Inspection – Release Detection													
1	Release detection equipment is operating with no alarms or other unusual operating conditions.												
2	Records of release detection (tanks and piping) are reviewed and current.												
Monthly Inspection – Spill Prevention Equipment													
3	Equipment is undamaged, intact and free from defects.												
4	Equipment is free from debris, water, or product.												
5	Fill Pipe is unobstructed.												
6	Fill cap is un-broken and is securely on the fill pipe.												
7	Double walled spill prevention equipment - Interstitial area is free from leaks.												
Initials of person performing inspection.													
Annual Inspection – Containment Sumps		Date of annual inspection											
8	Secondary Containment Sumps (STP, Dispenser and Transition)	Visual Inspection of sump indicates no damage and it is free from debris, water and fuel.											
		The penetration fittings for conduits and piping entering the STP Sumps are intact.											
9	Double Walled Sumps	Interstitial area is free from leaks.											
10	Hand-held release detection equipment	Hand-held release detection equipment (bailer, gauge stick, etc.) is serviceable and operable.											
I certify under penalty of law that I am the Class B Operator referenced above and that I am familiar with information on this form and that it is true, accurate and was completed in accordance with R311-203-7.													
Signature of the Primary Class B Operator (Sign this document after the last inspection of the Current Year)											Date		
B Operator #													

Comments/Follow up:

UST OPERATOR INSPECTIONS

Filling Out The Inspection Form

General Instructions

- Fill in the Year, Facility Name, Facility ID#, Address, print the name of the primary Class B operator.
- Questions 1-7 use Y(Yes), N(No), or NA(Not Applicable)
 - Do not use an X or √ in these boxes
- The individual conducting the inspection must initial each month in the box below line 7

Monthly Inspection (1-7)

Release Detection

#1 (on the form)

- Check release detection equipment on a regular basis
- Unusual operating conditions may include:
 - An Alarm
 - A Spill or Overfill
 - Dispensers not working
 - Sudden Loss of product

#2 (on the form) Release Detection records may include one or more of the following

- ATG results for each month
- Liquid Status Report for each month
- Containment Sensor Reports - monthly
- SIR reports for each month
- Line Tightness Tests - annual
- Line Leak Detector Tests - annual



UST OPERATOR INSPECTIONS

Filling Out The Inspection Form

Spill Prevention Equipment

#3-7 (on the form) Spill Buckets

- Inspect the equipment identified on that line
- Fill out boxes 3-7 for the appropriate month
- If problems are encountered make a note in the comment section at the bottom of the form and describe how the problem was resolved

Annual Inspection (8-10)

Containment Sumps

#8-10 (on the form) Tank Top, Dispensers and Transition Sumps

- Indicate the date of the annual inspection in the box above line 8
- Inspect the equipment identified on the line
- Enter the appropriate response (Y, N, NA) in the box at the right
- If problems are encountered make a note in the comment section at the bottom of the form and describe how the problem was resolved

***Best business practices would include more frequent inspections of the equipment listed on lines 8-10**



UST OPERATOR INSPECTION

Filling Out The Inspection Form

Page Two of the Form – if applicable

- Fill out the first table if you use a monthly visual check rather than a sump sensor for interstitial monitoring
- The second table is for Impressed Current Systems only

UST Operator Inspection - Utah – Page 2 of 2

If you perform Interstitial Monitoring on your tanks and/or piping and use a visual check rather than sump or interstitial sensors for your monthly leak detection, complete the table to document the monthly visual checks.													
		Months of the Current Year											
		J	F	M	A	M	J	J	A	S	O	N	D
1	Visual check of the interstitial space of the double-walled tank indicated no release or unusual operating conditions.												
2	Visual check of piping (STP, dispenser and transition) containment sumps indicates normal function and no indication of water or leaked product.												

Impressed Current 60 Day Rectifier Check													
		J	F	M	A	M	J	J	A	S	O	N	D
Show the date the Impressed Current system was inspected to ensure the equipment is running properly													
Amperage reading from impressed current rectifier													
Voltage reading from impressed current rectifier													

INSTRUCTIONS

1. The monthly UST system inspections must be conducted by or under the direction of the Primary Class B UST Operator.
2. The Primary Class B UST Operator must alert the UST Owner or Operator of any condition discovered during the monthly visual inspection that may require follow-up actions.
3. The UST Owner or Operator must maintain a copy of the monthly inspection reports for the most recent 12 months. The records shall be maintained on-site or off-site at a readily available location.

Ver. 4/14/2016



What you need to have on site

- Class B operator or qualified representative
- Monthly Operator Inspection Form
- Documentation of Repairs
- List of Class C operator training
- Leak Detection Records (one or more may apply)
 - ATG reports
 - SIR reports
 - Liquid Status Reports
 - Manual Tank Gauging Records
 - Line and Leak Detector Tests
 - 60 day Rectifier Check
 - Cathodic Test Reports

Visual Checks with inspector

- Be prepared to open containment sumps, spill buckets and dispensers (have necessary keys and tools available)
- Ensure all leak detection and cathodic protection equipment is accessible for inspection
- **Safety note:** it is always a good idea to have safety cones and a reflective vest



Notification

EPA Form 7530-1, Notification for Underground Storage Tanks, must be completed, revised, and submitted to the DERR when:

- New USTs are installed
- Ownership changes – within 30 days
- Changes made to the tank or piping system
- Release detection, corrosion protection, spill or overflow prevention systems are installed, changed or upgraded
- Change in fuel type, including alternative fuels



FINANCIAL RESPONSIBILITY AND CERTIFICATE OF COMPLIANCE

Financial Responsibility

- State and Federal UST regulations require that owners and operators of USTs demonstrate financial responsibility to show they can pay the costs of clean-up and third-party claims for leaks from USTs
- Owners/Operators may show Financial Responsibility through one of the following
 - Participation in the Petroleum Storage Tank Trust Fund (PST Fund)
 - Demonstrate financial responsibility through one of the following:
 - Self Insurance
 - Insurance coverage
 - Letter of Credit
 - Trust Fund
 - Surety Bonds
 - Corporate Guarantee

Certificate of Compliance

- The Utah UST ACT requires that owners and operators of regulated USTs qualify their tanks for and receive a Certificate of Compliance and keep the tanks in substantial compliance.
- It is a violation to operate an UST without a Certificate of Compliance



New Installations

Owners/Operators are required to notify the DEQ ten days prior to beginning the work. An installation permit and fee of \$200 per tank is required and must be obtained prior to the completion of the installation. The local fire jurisdiction and health department must be contacted for any requirements that they may have associated with the installation.

UST Installation Permit

- Utah Certified UST Installer who is directing all critical operations associated with tank installation
- Installation company name, address and current UST Installation Company Permit number. (Process Installation Company Permit Protocol, Appendix C-3)
- Date the work will commence
- Tank owner name and address
- Facility name and address
- Complete description of what is to be installed: tank or piping, capacity, material of construction, substance to be stored, etc
- Integrity testing of the containment sumps and spill buckets



Red Tag Program and One Time Drop

Red Tag

Delivery prohibition tags will be placed on new USTs during the installation process, to help ensure that no unauthorized deliveries (other than the one time drop) are made to the UST before it qualifies for a Certificate of Compliance. When the new UST does qualify for a certificate, the DEQ will issue the certificate and a letter authorizing the removal of the delivery prohibition tag.

One Time Drop Letter

Before the UST can be put into use, the integrity of the UST and associated piping must be evaluated through a tank and line tightness test. To receive fuel for the test, the owner or installer must contact the DEQ for authorization of a one-time delivery. After the initial drop, the USTs may not receive subsequent deliveries of fuel until they are issued a Certificate of Compliance and a letter authorizing the removal of the delivery prohibition tags.



CERTIFICATE OF COMPLIANCE

The Utah UST Act requires that Owners/Operators of regulated petroleum USTs qualify their tanks for and receive a Certificate of Compliance, and keep the USTs in substantial compliance with all UST rules and regulations. It is a violation of the UST Act to operate these USTs without a certificate. New USTs must have a certificate before being put into operation. Fines may be assessed if product or other regulated substance is delivered to or placed into an UST that does not have a Certificate of Compliance.



CLOSURES

There are two types of UST closures: temporary or permanent. All regulated USTs that do not meet the federal upgrade requirements must be permanently closed. Regulated USTs that meet federal upgrade requirements can be temporarily closed for periods when the tanks will not be in operation.

▶ Temporary Closure

- Seasonal use USTs which are only in operation during part of the year
- USTs are not in operation, but the owner has not decided to permanently close them

Less than Three Months

- Operate and maintain cathodic protection (if any)
- Operate and maintain leak detection (if any) or empty the tank to less than one inch of product

Three Months or More

- Operate and maintain cathodic protection (if any)
- Operate and maintain leak detection (if any) or empty the tank to less than one inch of product
- Submit a Temporary Closure Notice
- Leave vent lines open but cap and secure all other lines, pumps, manways and ancillary equipment
- Maintain corrosion protection and leak detection then the tank can remain temporarily closed indefinitely



Permanent Closure

Regulated USTs that do not meet federal upgrade requirements must be permanently closed. Permanent closure entails the removal of the UST from the ground or in place closures may be approved by the local fire department and the DEQ. To properly close an UST in Utah, an owner must:

- Contract with a Utah Certified Remover
- File a Closure Plan, and obtain approval
- Notify the local fire department, LHD and the DEQ 72 hours prior to closing the tank
- Close the tank either by removing it or by filling it with an inert substance, like sand or cement slurry
- Have a Utah Certified Soil/Groundwater Sampler collect the necessary environmental samples and have them analyzed at a certified laboratory
- If contamination is present, the Owners/Operators and/or the certified person must notify the DEQ within 24 hours
- Submit the Closure Notice with the sample analytical results within 90 days of closure
- In the case of in-place closures, meet the requirements of the Division of Solid Waste Management and Radiation Control by placing a notice on the title of the property



CLOSURES

Closure Plan

A completed Closure Plan must be submitted by the Owner/Operator and approved before commencing closure of the UST. A contractor may complete the Closure Plan; however, the Owner/Operator is responsible for compliance with all rules and regulations. Information on the Closure Plan includes:

- Once approved the Closure Plan is valid for one year
- Changes to an approved plan must be submitted in writing to the DERR and approved before closing the UST
- A copy of the approved Closure Plan must be on-site during closure activities

Closure Notice

Within 90 days of closing the UST, the Owner/Operator must submit the following:

- Completed Closure Notice signed by the Owner/Operator and the certified soil/groundwater sampler
- Updated site map and sample information table with the actual depths and locations of all soil and water samples, including depth of groundwater
- Analytical results of all samples
- Chain of Custody form, which tracks the samples from the time they were collected until they were delivered to the laboratory



RELEASE RESPONSE

Release: is any spilling, leaking, emitting discharge, escaping, leaching or disposing from an UST in groundwater, surface water or subsurface soils

Spills: occur during customer's use at the dispenser or during the filling of an UST at the tank fill pipe and impact the ground surface

Overfills: occur when an UST tank is filled beyond its capacity resulting in a discharge of product to the environment

Reporting

- Releases of any amount to waterways or surface water must be reported within 24 hours
- Spills over 25 gallons must be reported within 24 hours
- Spills less than 25 gallons that are not cleaned up must be reported within 24 hours
- Spills less than 25 gallons that are cleaned up within 24 hours do not have to be reported



RELEASE RESPONSE

Suspected Release may include:

- Overfill Alarm
- ATG Alarm
- Failed ATG test
- Failed SIR report
- Fuel Alarm
- Sudden loss of product
- Any other unusual operating condition
- Owners and Operators must report a suspected release or unusual operating condition to the DERR within 24 hours of the spill, overfill or release

Suspected Release Confirmation Steps

- Owners/Operators must investigate and confirm within 7 days that a suspected release of a substance occurred
- If the Owner/Operator cannot obtain a passing test or justify the alarm, the owner must notify the DERR

Response

- Owners/Operators must be prepared to respond to a release before it happens
- Stop the release
- Contain the release or spill or overfill
- Call for help



Fee Schedule FY 2017

- PST and Registration Fees are due by July 1 of each year
- This is not a complete fee schedule, see our website for more information

New Installations

- PST - \$150/tank
- Registration Fee : \$110/tank if on the PST Fund, \$220 if not on the PST Fund

Existing Facilities

- PST Fees based on through-put. Cut off is 70,000 gallons per facility per year
 - Over - \$150/tank
 - Under - \$450/tank
- Registration Fee
 - \$110/tank if on the PST Fund
 - \$220/tank if not on the PST Fund
 - \$300/tank if out of compliance for more than six months
- Late Fees - \$60
- Certifications - \$225/two years
- AB operator certification - \$50/three years

